



HAL
open science

A convex mathematical program for pump scheduling in a class of branched water networks

Gratien Bonvin, Sophie Demasse, Claude Le Pape, Nadia Maïzi, Vincent Mazaauric, Alfredo Samperio

► **To cite this version:**

Gratien Bonvin, Sophie Demasse, Claude Le Pape, Nadia Maïzi, Vincent Mazaauric, et al.. A convex mathematical program for pump scheduling in a class of branched water networks. *Applied Energy*, 2017, Clean, Efficient and Affordable Energy for a Sustainable Future, 185 (2), pp.1702-1711. 10.1016/j.apenergy.2015.12.090 . hal-01255929

HAL Id: hal-01255929

<https://hal-mines-paristech.archives-ouvertes.fr/hal-01255929>

Submitted on 29 Jan 2018

HAL is a multi-disciplinary open access archive for the deposit and dissemination of scientific research documents, whether they are published or not. The documents may come from teaching and research institutions in France or abroad, or from public or private research centers.

L'archive ouverte pluridisciplinaire **HAL**, est destinée au dépôt et à la diffusion de documents scientifiques de niveau recherche, publiés ou non, émanant des établissements d'enseignement et de recherche français ou étrangers, des laboratoires publics ou privés.

A Convex Mathematical Program for Pump Scheduling in a Class of Branched Water Networks

Gratien Bonvin^{a,b,*}, Sophie Demasse^a, Claude Le Pape^b, Nadia Maïzi^a, Vincent Mazauric^{b,a}, Alfredo Samperio^b

^aCentre for Applied Mathematics, MINES ParisTech, PSL* Research University, BP 207, 06902 - Sophia Antipolis, France

^bSchneider Electric, Strategy & Technology, 38TEC, 38050 - Grenoble cedex 9, France

Abstract

We address the day-ahead pump scheduling problem for a class of branched water networks with one pumping station raising water to tanks at different places and levels. This common class is representative of rural drinking water distribution networks, though not exclusively so. Many sophisticated heuristic algorithms have been designed to tackle the challenging general problem. By focusing on a class of networks, we show that a pure model-based approach relying on a tractable mathematical program is pertinent for real-size applications. The practical advantages of this approach are that it produces optimal or near-optimal solutions with performance guarantees in near real-time, and that it is replicable without algorithmic development. We apply the approach to a real drinking water supply system and compare it to the current operational strategy based on historical data. An extensive empirical analysis assesses the financial and practical benefits: (1) it achieves significant savings in terms of operation costs and energy consumption, (2) its robustness to dynamic pricing means that demand-response can be efficiently implemented in this type of energy-intensive utility.

Keywords: pump scheduling, branched water networks, demand-response, Mixed-Integer Non-Linear Programming, convex relaxation

1. Introduction

In typical drinking water distribution networks, water is collected, treated, and pressurized at pumping stations, then raised to elevated tanks and water towers, and finally supplied by gravity to local customers [1].

In developed countries, water utilities are among the largest consumers of energy in municipalities, and nearly all of the electricity purchased is used for pumping [2]. The motives for installing computer control systems in such water utilities have been documented for decades [3]: high operating costs, system complexity, rising demand, need to capitalize on staff experience, etc. The conjugated growth of electricity prices and environmental awareness has spurred new interest in the optimal control problem, also known as the *Pump Scheduling Problem*, because of its ability to address energy efficiency mechanisms such as demand-response [4, 5]. Because they are energy intensive and thanks to their buffering abilities, drinking water distribution networks are indeed remarkable instruments for implementing demand-response programs via load-shifting: by storing water and energy in elevated tanks,

demand can be anticipated by pumping the adequate amount of water when electricity is cheapest. Hence, given reliable water consumption forecasts and dynamic electricity prices, significant energy and financial savings can be achieved by shifting the pump operations to off-peak [5, 6].

Due to the problem's complexity, which is even greater when prices are highly dynamic, only automatized control programs have the computational capacity to determine a least-cost pump schedule in a general real-size utility. This issue has given rise to abundant literature on sophisticated heuristic algorithms (see e.g. the surveys in [3, 7, 8, 9, 5]). However, many small to medium-sized water supply systems, such as the French rural distribution network we examine in this paper, still rely on human operators to manage pumps in near-real time and expect them to do so in a cost-effective way [10]. One probable reason is that these practical solutions, including commercial products [11, 12, 13], require a minimum of algorithmic development and expertise to be replicated. Furthermore, these heuristics do not guarantee optimality and, thus, cannot be used to assess the maximum potential financial benefit.

By focusing on a specific, still widespread, class of networks, we show in this paper that a pure model-based approach is possible to tackle real applications, with several practical advantages. First, this approach is easy to replicate on any network in the class, since only the mathematical model's input data need to be changed; the resulting model can then be handled by any certified mathematical programming solver. This feature is convenient for net-

^{*}This paper was presented at the 7th International Conference on Applied Energy (ICAE2015), March 28-31, 2015, Abu Dhabi, UAE (Original paper title: "A heuristic approach to the water networks pumping scheduling issue" and Paper No.: 597).

*Corresponding author

Email address: gratien.bonvin@mines-paristech.fr (Gratien Bonvin)

work operators who wish to quickly prototype the optimal control of their utilities to estimate the benefit. Second, the model is tractable and can be quickly solved. Our control approach can then even be considered to operate in near real-time. Third, the approach is exact, i.e. it can guarantee the maximum possible financial benefit. Finally, since it is robust to highly-dynamic electricity prices, it is suitable for implementing demand-response.

The networks considered in this paper have the following characteristics: (1) a branched layout (i.e. no loop, no bi-directional pipes), (2) several pumps collocated in one pumping station at the source node, and (3) elevated tanks equipped with flow-control valves at the destination nodes. While such a topology can be encountered in industrial usages or in irrigation systems [14], it is particularly common in rural drinking water distribution networks [1]: in the upstream pumping network, water is treated and pumped near the source to be raised and dispatched to water towers where valves compensate for the elevation differences. The downstream gravity-fed network – from the towers to the consumers – is independent since the pressures in both networks are not correlated. To our knowledge, this class of networks has not been specifically investigated in prior studies. Notably, benchmark problems and real applications in literature tend to concern urban networks with looped configurations.

Our approach is based on a traditional formulation of the pump scheduling problem as a Mixed-Integer Non-Linear program (MINLP). This non-convex model has not been solved in reasonable time in general cases even involving small networks [15]. We thus consider a tractable relaxation by dropping non-convexities, precisely, the strict equality in the potential-flow coupling constraints. For the considered class of networks, we show how to convert a solution of this relaxation into a feasible solution with a limited cost increase. The increase is even null (i.e. the solution remains optimal) when the characteristic power functions of the pumps share the same slope.

The study was conducted by an industrial application on the FRD network, a medium-sized drinking water distribution system (6 pumps, 16 tanks, 49 nodes, 53 arcs) located in a rural zone of France and supplying about 3 million m^3 of water per year. Experiments on one year of historical data show the practical benefits of the approach compared to the in-house strategy currently employed in the utility: pumping plans for the day-ahead are generated in less than one minute and their feasibility is assessed on the EPANET simulator. On average, over one year, their cost is guaranteed to be less than 3% of the optimum, and they are 17% cheaper than the plans generated heuristically by the current strategy. In addition, the daily plans involve lower discharge pressures (22% lower on average) and thus fewer leakages. Incidentally, they operate the pumps with a 10% lower mean efficiency, which indicates that the current design of the station is sub-optimal. Finally, the current strategy is driven by night/day electricity tariffs and is not compatible with an intra-day price

variability, unlike our approach.

The paper is organized as follows: Section 2 provides a selected review of literature on the Pump Scheduling Problem. Section 3 presents the traditional MINLP formulation and Section 4 the convex relaxation for the considered class of networks. Section 5 provides an extended empirical analysis on the FRD network. Section 6 gives conclusions and perspectives.

2. Literature review

Pump Scheduling involves planning the pumping operations over a future period, typically the day ahead, in order to minimize energy costs, considering the static physical characteristics of the network elements (pipes, pumps, valves, tanks) and forecasts of the electricity price and water demand. An accurate mathematical model for this problem is hard to optimize as it involves both nonlinearities (the potential-flow relations) and combinatorial aspects (i.e. when active elements, pumps and valves can be switched on/off) [15, 16].

This problem has been the focus of significant attention over the last 40 years. Several survey papers [3, 7, 9] have reviewed the state-of-the-art. Altogether, they cite more than 80 references that we summarize here: earlier works mostly applied dynamic programming or continuous linear/non-linear programming techniques, often combined with hydraulic simulators, to handle the complex physics out of the optimization models. These time-consuming methods either consider basic networks (one pump, one tank) or oversimplify the problem.

Later on, many metaheuristic procedures were developed, including a number of evolutionary algorithms reviewed in the comprehensive survey [8] and, recently, less traditional procedures such as particle swarms [16] or metaheuristics, i.e. mathematical programming-based heuristics [17]. Several works report good results on medium-size benchmark instances or industrial applications: they are computationally efficient and can handle complex facets of the problem (e.g. multiple objectives [18] or side constraints). On balance, they do not guarantee global optimality and require sophisticated algorithm developments.

To tackle these drawbacks, model-based approaches rely on mathematical formulations to be solved using any suitable general-purpose solvers. Recent advances in Mixed-Integer Non-Linear Program (MINLP) solvers have renewed the interest in these approaches, as reported in a very recent survey [15]. However, the global (even local) solvers that are currently available do not yet scale up on the hard MINLP formulation of the pump scheduling problem. Hence, the approaches based on mathematical programming in current literature rely on relaxed models. Three kinds of relaxations are considered: the discrete decision components are ignored [19, 20]; the non-convexities are approximated using piecewise linear functions [21, 22, 23, 24]; or the time-coupling constraints are

dropped [25]. The resulting programs (a continuous non-convex program, a mixed integer linear program, or several small independent MINLPs) are more tractable, although they remain NP-hard. A trade-off is thus required between the strength of the approximation (e.g. the number of segments in the piecewise linear fit) and the expected computation time. Furthermore, these approaches rely on a heuristic algorithm to recover the feasibility of the relaxed solutions in a second phase. As a direct evolution of relaxation techniques, two recent works apply decomposition techniques (lagrangian relaxation [5] and Benders decomposition [26]): to get an optimal solution, the relaxation is solved iteratively driven by a master program. Again, as the convergence is too slow, the method is truncated and coupled with Local Search [5]. Hence, the mathematical programming-based approaches that were published for the Pump Scheduling Problem are not pure model-based approaches: they are generic and some are applicable to large networks, but they generally do not provide optimality proofs, many are time-consuming, and all require more or less experimented skills to be implemented properly. In comparison, we focus in this article on a less general (yet widespread) class of networks but, precisely, we show how to exploit these specificities to derive a fast exact replicable pure model-based approach.

3. MINLP for Pump Scheduling

The Mixed-Integer NonLinear Programs designed for the general Pump Scheduling Problem share the same structure. For the class of networks considered in this article, this formulation can be slightly simplified. This section first details the topology of the considered class of networks, then the traditional MINLP formulation adapted to this class.

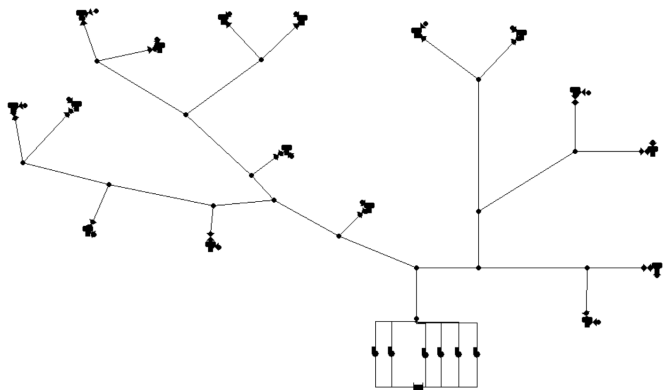

Figure 1: FRD network: a pumping station operating 2 small and 4 large pumps in parallel and supplying 16 water towers equipped with flow control valves.

3.1. Notation and variables

In the considered class of water networks, illustrated by Figure 1, a pumping station is connected to a pipe network in which water is transported to the elevated water

tanks. These can naturally be represented by a multi-arc K connected to an arborescence, i.e. a directed rooted tree, (J, L) :

- each arc $k \in K$ models one pump and links the inlet reservoir node r to the outlet station node s ;
- the set J of nodes in the arborescence includes the station node s (the root), the tanks J_T (the leaf nodes), and the pipe junctions J_J (the internal nodes);
- the set L of directed arcs consists of the pipes L_P and the flow control valves L_V . In our context, there is exactly one valve before each tank. In the arborescence (J, L) , the valves are then represented by the terminal arcs to the leaves (from a junction to a tank), while the pipes are represented by the internal arcs (from the station node or between two junctions).

The planning horizon is one day divided into $T = 24$ hourly periods.

The mathematical model involves two sets of decision variables: the activity indicator $x_{kt} \in \{0, 1\}$ of pump $k \in K$ (i.e. $x_{kt} = 1$ if k is on at time t , $x_{kt} = 0$ otherwise) and the flow rate $q_{lt} \geq 0$ (in m^3/h) passing in a directed link $l \in L$ or pump $l \in K$ in time period $t \in [1, T]$. Since each time period t lasts 1 hour, q_{lt} is also the volume (in m^3) of water flowing through element l during period t . The model also involves one set of implied variables: the hydraulic head (or node potential) $h_{jt} \geq 0$ (in m) at node $j \in J$ in time period $t \in [1, T]$. This is conventionally measured as the sum of the geographical elevation and the water pressure head at the node.

J	nodes	L	arcs
r	reservoir node	K	pumps
$s \in J$	station node	$L_P \subset L$	pipes
$J_T \subset J$	tank nodes	$L_V \subset L$	valves
$J_J \subset J$	internal nodes	$t \in [1, T]$	time periods
$x_{kt} \in \{0, 1\}$	activity indicator of pump $k \in K$ in period t		
$q_{lt} \geq 0$	flow/volume through $l \in L \cup K$ in period t		
$h_{jt} \geq 0$	hydraulic head at node $j \in J$ in period t		

Table 1: Summary of notation

3.2. Potential-flow coupling

The physical behavior of a pump or a pipe is accurately modeled by a real function of the instantaneous flow rate passing through it:

Pipes. Darcy-Weisbach is the preferred law to describe the pressure loss along a pipe $ij \in L_P$ (as a function Φ_{ij} of the flow q) in water networks [27]. This equation relies on a coefficient, the friction factor, which is itself an implicit function of the flow [21]. To obtain a tractable expression within a mathematical model, this coefficient

is generally approximated using the Prandtl-Kármán formula for fully turbulent flows (with a Reynolds number Re greater than 10^6) as in [23, 25] or using the Swamee-Jain formula for turbulent flows ($Re > 4000$) as in the modeling software EPANET [28]. To keep our model both accurate and tractable, and to make it compatible with EPANET for checking the feasibility of the solutions, we follow Eck et al. [27] and approximate the latter expression as a quadratic function

$$\Phi_{ij}(q) = A_{ij}q + B_{ij}q^2$$

over range $4000 \leq Re \leq 10^5$ using a least squared regression method.

235 *Pumps.* The characteristics of a fixed speed pump $k \in L$ are given by the manufacturer as a set of experimental points that we propose to interpolate as depicted in Figure 2.

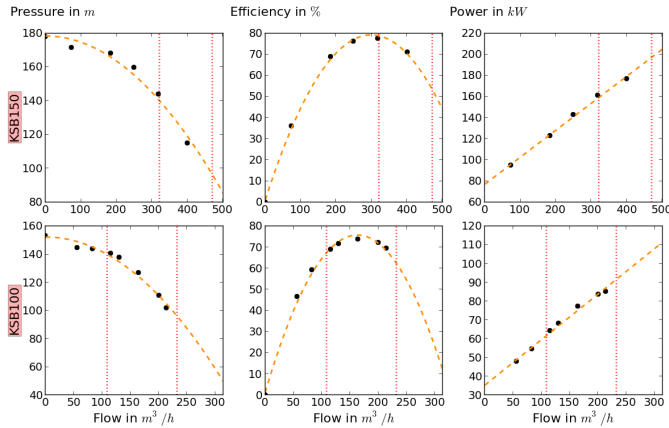

Figure 2: Pressure discharge (left, in m), efficiency (middle, in %), and power consumption (right, in kW) of the two classes of pumps available at the FRD pumping station: experimental observations (in black) and fitted curves (in orange).

For the two considered classes of pumps, the pressure discharge can accurately be approximated by a quadratic function (as in [15]) of the flow:

$$\Psi_k(q) = A_k - B_kq^2.$$

Rather than expressing the power consumption as a function of pressure, flow and efficiency, we adopt a linear approximation:

$$\Gamma_k(x, q) = P_k^0x + P_kq,$$

240 where q is the flow rate through the pump and x the activity indicator of the pump. Note that, by definition¹, the flow through a pump is null ($q_{kt} = 0$) if and only if the pump is inactive ($x_{kt} = 0$). The contribution to the cost is then null ($\Gamma_k(x_{kt}, q_{kt}) = 0$) when pump k is inactive at time t . Such a linear fit has been considered in previous

works (e.g., [21, 23, 20]). In our case, it provides a very good approximation as illustrated by the graphs on the right of Figure 2.

Finally, the pump efficiency is the ratio between the hydraulic power $\rho g q \Psi_k(q)$ (where $\rho = 1000 \text{ kg/m}^3$ the water density and $g = 9.81 \text{ m/s}^2$ the gravitational acceleration) and the power consumed. Again, this quantity denoted $\eta_k(q)$ is well defined by a quadratic function (as in [23]).

3.3. Mathematical model

Given the notation summarized in Table 1, the Pump Scheduling Problem can be formulated as follows:

$$z = \min \sum_{t \in T} \sum_{k \in K} C_t \Gamma_k(x_{kt}, q_{kt}) \quad (1)$$

$$\text{s.t.} \quad \sum_{ij \in L \cup K} q_{ijt} = \sum_{ji \in L} q_{j it}, \quad \forall t, j \in \{s\} \cup J_J \quad (2)$$

$$\sum_{ij \in L} q_{ijt} = S_j(h_{jt} - h_{j(t-1)}) + D_{jt}, \quad \forall t, j \in J_T \quad (3)$$

$$h_{j0} = H_j^0, \quad \forall j \in J_T \quad (4)$$

$$H_j^{\min} \leq h_{jt} \leq H_j^{\max}, \quad \forall t, j \in J_T \quad (5)$$

$$h_{it} - h_{jt} \geq 0, \quad \forall t, ij \in L_V \quad (6)$$

$$Q_k^{\min} x_{kt} \leq q_{kt} \leq Q_k^{\max} x_{kt}, \quad \forall t, k \in K \quad (7)$$

$$(h_{st} - h_{rt} - \Psi_k(q_{kt}))x_{kt} = 0, \quad \forall t, k \in K \quad (8)$$

$$h_{it} - h_{jt} = \Phi_{ij}(q_{ijt}), \quad \forall t, ij \in L_P \quad (9)$$

Objective (1) minimizes the total energy cost of pumping where C_t denotes the electricity tariff (in €/kWh). Flow conservation is ensured by Constraints (2) at the station node s and at each junction $j \in J_J$, and by Constraints (3) at each tank $j \in J_T$. In Constraints (3), D_{jt} denotes the demand (in m^3) in time period $t \in [1, T]$ and S_j the cross-section (in m^2) of the cylindrical tank: as the water in the tank is at atmospheric pressure [19], the hydraulic head h_{jt} represents the elevation head of the filling level, i.e. the elevation of the tank plus the volume of water divided by S_j . The volume of water in a tank, and thus the hydraulic head, are bounded at any time (5) and fixed at time 0 (4). Constraints (6), (8) and (9) model the potential difference along, respectively, valves (as in [20]), pumps and pipes. Finally, Constraints (7) and (8) model the activity of the pumps: Constraints (7) enforce the flow to be null when the pump is inactive, and within some positive interval $[Q_k^{\min}, Q_k^{\max}]$ otherwise. Constraints (8) enforce a fixed potential difference between the station inlet r and outlet s only if at least one pump is active. If all pumps are off ($x_{kt} = 0, \forall k \in K$), the hydraulic heads at nodes r and s are left unrelated.

4. Towards a tractable model

Due to its non-convexities, model (1-9) above is likely hard to resolve at optimality. We show in this section how to exploit the specificities of the considered class of networks to turn this model into a tractable convex MINLP.

¹this definition is enforced by Constraints (7) in our model.

4.1. One-direction flow

Compared to the general formulation, the MINLP above³¹⁵ presents a first simplification that is valid for any branched networks: pipes and valves allow for flows in only one direction. In the general case, either the flow variables q_{ijt} on pipes are not restricted in sign (as in [25]), leading to nonsmooth and nonconvex constraints (9), or the pipes are duplicated ($q_{ijt} \geq 0, q_{jit} \geq 0$) in the model and linked by additional binary variables (with $x_{ijt} + x_{jit} \leq 1$) to model the flow direction (as in [27]). For valves, equivalently, either a nonconvex constraint [19] or an additional binary³²⁰ variable [25] is required in place of a linear constraint (6) to ensure that the valve pressure decrease is consistent with the direction of the flow.

4.2. Symmetric pumps

A pumping station commonly contains pumps with similar characteristics and ages. The set K of pumps can then be partitioned into classes $\mathcal{C}(K)$. Since all of the active pumps in a class work on the same operating point according to (8), these pumps can be aggregated in the³³⁰ model. One way of doing this [20] is to model the number of active pumps as an integer variable instead of the binary activity status x_{kt} of each individual pump. This reduces the number of head-flow constraints (8) to only one per pump class. An alternative [25] is to order the pumps³³⁵ in a class arbitrarily and enforce the following symmetry breaking constraints:

$$x_{(k+1)t} \leq x_{kt}, \quad \forall t, \mathcal{C} \in \mathcal{C}(K), k, k+1 \in \mathcal{C} \quad (10)$$

The benefits of aggregation or symmetry breaking are twofold.³⁴⁰ First, it helps the computation of the MINLP by reducing both its size and the size of its search space (from $2^{|K|}$ to $\sum_{\mathcal{C} \in \mathcal{C}(K)} |\mathcal{C}| + 1$); note that in our experiments, the two approaches resulted in similar improvements. Second, it decomposes the operational problem into two steps:³⁴⁵ the MINLP determines how many pumps per class to activate, while the operators of the pumping station determine which physical pumps to select. Based on their practical knowledge of the network elements, they can more naturally and efficiently enforce operational constraints³⁵⁰ and preferences regarding pump lifetimes and maintenance needs. For example, they can balance the activity across the pumps in order to limit the number of switches and the inactivity period of each pump per day.

4.3. Convex potential-flow coupling constraints

As suggested by Gleixner et al. [25], if a pipe $ij \in L_P$ and a pressure-reducing valve $l \in L_V$ are connected with zero demand at junction $j \in J$, then the pressure loss equation (9) for pipe ij can be relaxed into a lower bound:³⁶⁰

$$h_{it} - h_{jt} \geq \Phi_{ij}(q_{ijt}), \quad \forall t, ij \in L_P \quad (9')$$

Indeed, the valve can dissipate any extra amount $h_{it} - \Phi_{ij}(q_{ijt}) - h_{jt} \geq 0$ of pressure at junction j .

In our case, a valve precedes each water tower and no water demand occurs at junctions. This allows us to relax the equality in all constraints (9) because on each path connecting the pumping station to a water tower, the flow ultimately goes through a valve. The valve then compensates for the artificial higher pressure losses along the path.

For the same reason, we propose to relax the potential-flow coupling equations (8) for pumps as

$$(h_{st} - h_{rt} - \Psi_k(q_{kt}))x_{kt} \leq 0, \quad \forall t, k \in K \quad (8')$$

to allow an artificial lower pressure h_{st} at the station outlet s . Again, we assume that the valves will dissipate the actual higher pressures at the junctions, when the operating point of each pump k is pushed up on the head-flow curve Ψ_k .

The following two propositions show that the relaxed MINLP (\mathcal{P}'): $(1 - 7, 8', 9')$ is equivalent to the original MINLP (\mathcal{P}): $(1 - 7, 8, 9)$ on the condition that the slopes of the power functions of the pumps are all equal. More precisely, and of practical interest, we show how to build a feasible solution for the original problem (\mathcal{P}) given a relaxed solution of (\mathcal{P}') by balancing the flow through the pumps (to push up the operating point of the pumps on their respective head-flow curves) and increasing the pressure progressively from the station to the dissipating valves (to propagate the actual lower pressure losses).

In Proposition 1, we consider the case in which all pumps are identical. We prove that both solutions cost the same: the derived solution is then optimal for (\mathcal{P}) if the relaxed solution is optimal for (\mathcal{P}'). Proposition 2 addresses the general case in which pumps of different classes can be active at the same time. The cost of the two solutions may then differ by a factor of $\max_{k \in K} P_k - \min_{k \in K} P_k$ in the worst case, where P_k is the slope of the power function Γ_k of each pump k . The conversion leads thus to the optimum of (\mathcal{P}) if the relaxed solution is optimal for (\mathcal{P}') and if all slopes P_k are identical. Otherwise, the derived solution may not be optimal for (\mathcal{P}) but the optimum of (\mathcal{P}') provides a lower bound for (\mathcal{P}) and thus an estimation of the optimal gap of the derived solution.

Proposition 1. *Assume all pumps in K are identical and let denote $\Psi_k = \Psi$ and $\Gamma_k = \Gamma$ for all pumps $k \in K$. For each solution (x, q', h') feasible for the relaxed program (\mathcal{P}'), there exists a solution (x, q, h) feasible for the original program (\mathcal{P}) and at same cost.*

Proof: We build a solution (x, q, h) that coincides with (x, q', h') with the possible exception of the values of the hydraulic pressures h_{jt} at the junctions $j \in \{s\} \cup J_J$ and the values of the flows q_{kt} through the active pumps $k \in K$.

First, the flow is evenly spread between the active pumps at each time step $t \in T$ according to: $q_{kt} = q'_t$ for all $k \in K$ such that $x_{kt} = 1$ with $q'_t = \frac{\sum_{k \in K} q'_{kt}}{\sum_{k \in K} x_{kt}}$. The pressure at the station outlet is set to $h_{st} = \Psi(q'_t)$ (using r as the reference point, we assume $h_{rt} = 0$ w.l.o.g.). Since Ψ is concave, then $h_{st} \geq \frac{\sum_{k \in K} \Psi(q'_{kt})}{\sum_{k \in K} x_{kt}} \geq \min_{k \in K | x_{kt}=1} \Psi(q'_{kt}) \geq h'_{st}$.

365 Pressures at junctions $j \in J_J$ are then computed for⁴¹⁵
each time step $t \in T$ recursively along the paths from
station s by: $h_{jt} = h_{it} - \Phi(q_{ijt})$ with $q_{ijt} = q'_{ijt}$ for all
 $ij \in L_P$. By induction from s , we prove that $h_{jt} \geq h'_{jt}$
for all $j \in \{s\} \cup J_J$: assuming $h_{it} \geq h'_{it}$ for some pipe
370 $ij \in L_P$, then $h_{jt} \geq h'_{it} - \Phi(q_{ijt}) \geq h'_{jt}$. As a conse-⁴²⁰
quence, (x, q, h) satisfies constraints (6) for all water tow-
ers $j \in J_T$, valves $ij \in L_V$ and time steps $t \in T$ since
 $h_{it} - h_{jt} = h_{it} - h'_{jt} \geq h'_{it} - h'_{jt} \geq 0$. All other con-
straints of (\mathcal{P}) are also satisfied by construction of (x, q, h) .
375 Finally, since Γ is linear, both solutions cost the same:⁴²⁵
 $z = \sum_{t \in T} \sum_{k \in K} C_t \Gamma(q_{kt}) = \sum_{t \in T} \sum_{k \in K} C_t \Gamma(q'_{kt}) = z'$.
■

Proposition 2. For each solution (x, q', h') feasible for
the relaxed program (\mathcal{P}') , there exists a solution (x, q, h) ⁴³⁰
feasible for the original program (\mathcal{P}) such that the cost dif-
ference is bounded from above by a factor of $(\max_{k \in K} P_k -$
 $\min_{k \in K} P_k)$.
380

Proof: The derived solution (x, q, h) is built as in Proposi-
tion 1 except for the distribution of the total flow through
385 the pumps at each time step t .

The flow conveyed by the active pumps of a given⁴³⁵
class $\mathcal{C} \in \mathcal{C}(K)$ can be evenly balanced as above. Let
 $n_{\mathcal{C}t} = \sum_{k \in \mathcal{C}} x_{kt}$ be the number of active pumps in class \mathcal{C}
and $q'_{\mathcal{C}t} = \frac{\sum_{k \in \mathcal{C}} q_{kt}}{n_{\mathcal{C}t}}$ be the flow through each active pump
390 of \mathcal{C} if evenly balanced, then the total flow at time t is⁴⁴⁰
 $\sum_{\mathcal{C} \in \mathcal{C}(K)} n_{\mathcal{C}t} q'_{\mathcal{C}t}$.

The flow must now be balanced among the pump classes
such that $\Psi_{\mathcal{C}}(q_{\mathcal{C}t}) = \Psi_{\mathcal{C}'}(q_{\mathcal{C}'t})$ for all classes $\mathcal{C}, \mathcal{C}' \in \mathcal{C}(K)$,
and such that total flow is conserved, i.e. $\sum_{\mathcal{C} \in \mathcal{C}(K)} n_{\mathcal{C}t}(q_{\mathcal{C}t} -$
395 $q'_{\mathcal{C}t}) = 0$. This system of $|\mathcal{C}(K)|$ equations and variables⁴⁴⁵
 $q_{\mathcal{C}t}$ admits exactly one solution as the pressure discharge
functions $\Psi_{\mathcal{C}}$ are bijective on the half-plane $q \geq 0$.

Let $h_{st} = \Psi_{\mathcal{C}}(q_{\mathcal{C}t})$ for any $c \in \mathcal{C}(K)$. The proof of
Proposition 1 applies to establish the feasibility of solution
400 (x, q, h) if we prove that $h_{st} \geq h'_{st}$: Since $\sum_{\mathcal{C} \in \mathcal{C}(K)} n_{\mathcal{C}t}(q_{\mathcal{C}t} -$ ⁴⁵⁰
 $q'_{\mathcal{C}t}) = 0$, there is at least one class $\mathcal{C} \in \mathcal{C}(K)$ such that
 $q_{\mathcal{C}t} \leq q'_{\mathcal{C}t}$. Given (8') and that $\Psi_{\mathcal{C}}$ is both concave and
decreasing, then $h_{st} = \Psi_{\mathcal{C}}(q_{\mathcal{C}t}) \geq \Psi_{\mathcal{C}}(q'_{\mathcal{C}t}) \geq h'_{st}$.

Finally, the cost difference at time t between the two
405 solutions is $\Delta \mathcal{C}_t = \sum_{\mathcal{C} \in \mathcal{C}(K)} C_t n_{\mathcal{C}t} P_{\mathcal{C}}(q_{\mathcal{C}t} - q'_{\mathcal{C}t})$. Let the⁴⁵⁵
set of classes $\mathcal{C} \in \mathcal{C}(K)$ be divided in $\mathcal{C}(K)^+$ and $\mathcal{C}(K)^-$
depending respectively on whether the flow is increased
($q_{\mathcal{C}t} \geq q'_{\mathcal{C}t}$) or decreased ($q_{\mathcal{C}t} < q'_{\mathcal{C}t}$), and let P^+ and
 P^- be respectively the highest and lowest slope of power
410 functions among the classes $\mathcal{C} \in \mathcal{C}(K)$. Then, $\Delta \mathcal{C}_t \leq$ ⁴⁶⁰
 $C_t P^+ \sum_{\mathcal{C} \in \mathcal{C}(K)^+} n_{\mathcal{C}t}(q_{\mathcal{C}t} - q'_{\mathcal{C}t}) + C_t P^- \sum_{\mathcal{C} \in \mathcal{C}(K)^-} n_{\mathcal{C}t}(q_{\mathcal{C}t} -$
 $q'_{\mathcal{C}t}) = C_t (P^+ - P^-) \sum_{\mathcal{C} \in \mathcal{C}(K)^+} n_{\mathcal{C}t}(q_{\mathcal{C}t} - q'_{\mathcal{C}t})$. The total
cost difference is thus bounded from above by a factor of
 $(P^+ - P^-)$. ■

Finally, the potential-flow coupling equations (8') can⁴⁶⁵
be reformulated as quadratic inequalities with the help of
big-M values:

$$h_{st} - h_{rt} \leq \Psi_k(q_{kt}) + M(1 - x_{kt}), \quad \forall t, k \in K \quad (8'')$$

By choosing a sufficiently large value for M (we use $M =$
 $\max_{k \in K} A_k - \min_{k \in K} A_k$), this constraint enforces $h_{st} -$
 $h_{rt} \leq \Psi_k(q_{kt})$ when pump k is active ($x_{kt} = 1$) and leaves
 h_{st} and h_{rt} unrelated otherwise.

The resulting model (\mathcal{P}'') : $(1 - 7, 8'', 9', 10)$ belongs
to the class of convex Mixed Integer Quadratically Con-
strained Programs (MIQCP), and thus has in practice
a lower computational complexity than (\mathcal{P}) . Indeed, it
can be handled by efficient solution algorithms capable
of reaching global optimality, such as the sophisticated
Branch-and-Bound and Outer Approximation algorithms
available in numerous general-purpose solvers. Further-
more, in order to derive a feasible solution for (\mathcal{P}) with a
performance guarantee, (\mathcal{P}'') does not need to be solved
to optimality, but only to provide at least one feasible so-
lution and a lower bound. In the experiments we present
below, we run the solver for a limited amount of time,
enough to compute this information.

5. Application to the case study

5.1. Study case and experimental set

In this section, we present the results of our experi-
ments conducted on the medium-size network FRD de-
picted in Figure 1: 16 water towers with valves are con-
nected by 31 pipes to a single pumping station equipped
with 4 pumps of class *KSB150* and 2 pumps of class *KSB100*
(the pump characteristics are depicted in Figure 2).

FRD is a real drinking water supply system located in
a rural zone of France. It serves an area of about 350 km^2
with a marked topography: the source is at elevation of
 $+40 \text{ m}$ while the highest reservoir is at $+131 \text{ m}$. The sys-
tem annually supplies about 3 million m^3 of water, with
twice as much in summer compared to winter. Currently
the pumping station is operated by an in-house heuristic
solution (this common strategy [10] is described in sec-
tion 5.3.1), with an annual consumption of about 1.3 GWh .
We have access to one year of historical data on the aggre-
gated water demand of the end-consumers at each water
tower. Data consist of measurements 10 or 15 minutes
apart that we average out into a 1-hour step. The electric-
ity tariff scheme we consider is the green tariff *A5 Base*
Very Long Uses provided by the French utility company
EDF [29]. This day/night pricing has two different tar-
iffs for summer (April to October) and winter (November
to March). Furthermore, a peak tariff applies during four
hours a day (two in the morning and two in the evening)
from December to February, and night pricing applies all
day Sunday.

We empirically evaluated our approach on 365 differ-
ent instances, each corresponding to a day of the historical
data. The water demands – and thus the instances – are
highly contrasted depending on the season; in particular,
demand increases significantly during the summer tourist
season. A 'day' starts and ends at 22h, which marks the
beginning of the night pricing, and the water tower vol-
umes are set to their minimum level at the beginning of

470 the day. Indeed, to minimize the total energy cost in practice, the water towers are emptied at the end of the day and filled at the beginning of the next day, i.e. during the night pricing period.

475 The solution approach is as follows: as explained in Section 3, curves Γ_C and Ψ_C for the two classes of pumps are fitted from the series of operating points provided by the constructor and the pressure loss function Φ_p is approximated using a quadratic function. Model (\mathcal{P}'') is then built with the Gurobi Python API and solved by the default MIQCP solver of Gurobi v5.6.3 using 8 threads of a quad-core processor 8GB RAM Intel Core i7 CPU 3720 @ 2.66 GHz running Windows 7 (64 bits). Note that this solver is also freely available on the NEOS server [30] through different interfaces. We allot 60 seconds to the computation time after which the solver returns the best lower bound and the best solution found. The solution is then converted into a feasible solution to the original problem (\mathcal{P}) according to the construction of Proposition 2. Note that, with only two different classes of pumps, the redistribution of the flows q_{ct} through the pump classes can be easily computed by analytically solving the system of two quadratic equations.

5.2. Validating the approach

485 The experiments were conducted on the 365 instances, but to investigate the results more in depth, we exhibited two representative days: a *winter day* and a *summer day*. To validate our approach on our case study, we answered the following questions:

490 *May the approach compute good solutions in short times ?*

495 For all 365 instances, Gurobi found a lower bound and at least one feasible solution for the convex relaxation (\mathcal{P}'') in less than 1 minute. The process to convert the best relaxed solution computed in 1 minute into a feasible solution for (\mathcal{P}) is immediate. We estimated for each day $d = 1, \dots, 365$ the gap G_d between the cost of the converted solution and the lower bound of (\mathcal{P}'') as a ratio of the lower bound. The mean gap $\frac{1}{365} \sum_d G_d$ and the maximal gap $\max_d G_d$ are respectively 3.0% and 8.2%. The gap includes the surplus cost arising from the conversion of the solution to (\mathcal{P}'') into a feasible solution to (\mathcal{P}) . This conversion cost represents only 0.17% of the overall gap: this is less than €0.01 per day on average.

500 *Is the convex relaxation required ?* We directly solved the non-convex formulation (\mathcal{P}) with the symmetry breaking constraints (10) under nine state-of-the art MINLP solvers available on the NEOS server [30]. Three solvers (Dicopt, Lindo Global, SBB) were unable to process the model because of its size. Four solvers (Bonmin, Couenne, Scip, Knitro) were unable to compute any feasible solution in less than 2 hours. The two global solvers AlphaECP and Baron computed good solutions in reasonable time for some instances but not for all. Figure 3 illustrates the behavior of these solvers compared to our approach on the

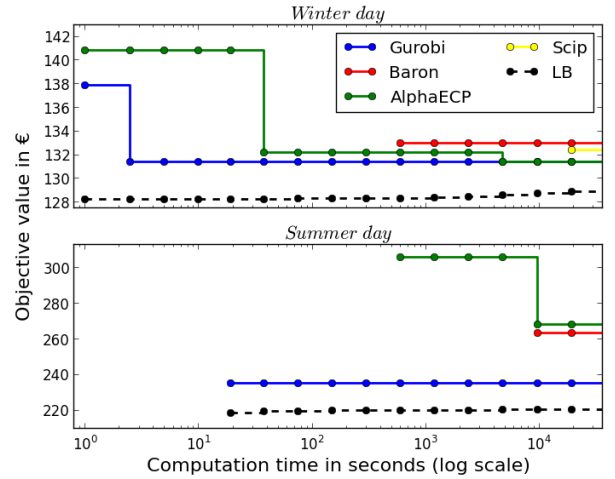

Figure 3: Comparison of the solutions (quality and computation time) found by MINLP solvers (AlphaECP, Baron, Scip) and by our approach (Gurobi) on the winter (top) and summer (bottom) representative days. LB denotes the value of the best lower bound computed by our approach.

525 typical *winter day* (top) and *summer day* (bottom). On the easier (winter) instance, our approach found the best solution in 2 seconds, at 2% from the best lower bound LB computed by our approach. AlphaECP was also able to compute instantly a solution, but of inferior quality at 9% from LB. The solution did not improve before 30 seconds and met our best solution after more than 1 hour. Note that Baron and Scip computed good first solutions but, respectively in 10 minutes and 5 hours. On the hard (summer) instance, none of the non-convex solvers were able to compute at least one solution in less than 5 minutes. The best solutions found after 2 hours by AlphaECP and Baron were respectively at 39% and 20% from LB. Our approach found its best solution at 7% from LB in less than 20 seconds. These experiments show that a direct non-convex solution approach is not practicable in this application case.

530 *Is the approach robust to increasing demands ?* We now detail our approach behavior on the two representative days. On the *winter day* d^W , the overall water demand is low ($6110 m^3$). For this instance and 229 similar others, only the two smallest pumps are activated in the computed solution. The solution for d^W is depicted in Figure 4b. Its optimality gap is $G_{d^W} = 2\%$. According to Proposition 1, the conversion cost from (\mathcal{P}'') and (\mathcal{P}) is zero.

535 On the typical *summer day* d^S , the water demand is doubled ($13505 m^3$). For this instance and 134 others, the largest pumps are also activated, supplying about 20% of the total flow. We observe that the solution optimality gap is greater when the daily flow is higher: for the day under study, the gap is $G_{d^S} = 7\%$. The conversion cost is negligible (€0.002) for two reasons. On the one hand, the slopes of the power functions of the small and large

pumps are close. On the other hand, the largest pumps⁶⁰⁰ are active only on few time steps. For 51 of the 135 summer instances, the conversion cost is even zero because, at time steps where flows need to be rebalanced, the active pumps are all of the same class.

Are the computed solutions physically viable ? We tested the solutions with EPANET. To match the hypothesis of this simulator, we made two slight changes to our model. First, we enforced the pressure loss functions to overestimate the pipe losses, i.e. we computed A_{ij} and B_{ij} with the constraint that $\Psi_{ij}(q)$ is greater than the theoretical pipe losses for the range of possible flow values. Secondly, we replaced constraints (6) on valves with

$$h_{it} - h_{jt} \geq Q_{ij}^{Max} / S_j, \quad \forall t, ij \in L_V \quad (6')$$

given Q_{ij}^{Max} an upper bound on inflows. This forces the water tower head to increase when inflows exceed demand. With these two modifications, we observed that our solutions are fully compatible with EPANET for both the *winter day* and the *summer day*.

5.3. Evaluating the gains achieved

In this section, we estimate the annual expected benefits arising from optimizing the pump schedule. To this end, we simulated the strategy currently implemented in the FRD network. Variants of this strategy are common in water utilities [10].

5.3.1. Current strategy

In practice, the operators manage the network by opening and closing gate valves at the water towers. Additionally, flow control valves fix the amount of water entering each tower. This amount results from the trade-off between securing the water supply and restricting pressure losses; it is only modified twice a year to correspond to seasonal demand. At each valve status change, if the induced discharge pressure decreases or increases sufficiently, the operators select pumps to switch on/off. In our simulation, the time is discretized into 15-minute periods, and the combination of pumps to activate in a given period is selected so as to satisfy the required total flow and minimize power consumption.

The operators decide to open or close a valve at a given time when the current volume of the water tower reaches thresholds: the valve is open (resp. closed) if the volume is within or passes beyond the lower (resp. upper) threshold and remains open (resp. closed) until it reaches the upper (resp. lower) threshold. To compute these thresholds, the operators take into account the electricity tariff and, very approximately, the future demand: the range allowed between the thresholds has been estimated through practice to avoid over-frequent changes in valve status, and the threshold levels depend on the tariff period. Precisely, at night, the upper threshold is set to the physical capacity of the tower and the lower threshold is set slightly below

this value in order to provoke pumping at the lowest tariff and store for the day ahead. Conversely, during the day, the lower threshold is set at the minimum water volume required in case of emergency and the upper threshold is set slightly above this value in order to limit pumping at the highest tariff.

5.3.2. Estimated benefits

To estimate and explain the energy cost savings, we consider the alternative formula of the cost as a function of the flow, pressure and efficiency², denoted as z_d for a day $d = 1, \dots, 365$:

$$\begin{aligned} z_d &= \sum_{t \in T} \sum_{k \in K} \frac{q_{ktd} \rho g \Psi_k(q_{ktd})}{\eta_k(q_{ktd})} C_{td} \\ &= \underbrace{\sum_{t \in T} C_{td} \sum_{k \in K} \frac{q_{ktd} \Psi_k(q_{ktd})}{\eta_k(q_{ktd})}}_{C_d} \underbrace{\sum_{t \in T} \sum_{k \in K} \frac{q_{ktd} \Psi_k(q_{ktd})}{\eta_k(q_{ktd})}}_{\eta_d^{-1}} \\ &\quad \times \rho g \underbrace{\sum_{t \in T} \sum_{k \in K} q_{ktd} \Psi_k(q_{ktd})}_{\Psi_d} \underbrace{\sum_{t \in T} \sum_{k \in K} q_{ktd}}_{Q_d} \end{aligned}$$

We then investigated the three factors of cost: the mean discharge pressure Ψ_d needed in order to supply the water demand, the mean efficiency η_d of the pumping station, and the mean cost C_d of the electricity consumed. Table 2 summarizes the values obtained by our approach (denoted *MINLP*) compared to the simulated current strategy (denoted *BAU*) aggregated on the annual scale, while Figures 4a and 4b illustrate them on the typical *winter day*.

	<i>BAU</i>	<i>MINLP</i>	$\Delta M/B$
power cost $\sum_d z_d$ (k€)	58.7	48.8	-16.9%
power consumption $\sum_d \Psi_d Q_d \eta_d^{-1}$ (GWh)	1.335	1.157	-13.3%
mean discharge pressure $\frac{1}{365} \sum_d \psi_d$ (m)	133.1	103.9	-21.9%
mean pump efficiency $\frac{1}{365} \sum_d \eta_d$	74.2%	67.2%	-9.6%
mean power cost $\frac{1}{365} \sum_d C_d$ (€/MWh)	45.0	43.1	-4.2%
night/total power consumption (%)	46.1%	54.1%	+17.4%
day/total power consumption (%)	51.0%	45.8%	-10.2%
peak/total power consumption (%)	2.9%	0.1%	-96.6%

Table 2: Annual energy cost and consumption: comparison between the simulated strategy (*BAU*) and our approach (*MINLP*). The deviation $\Delta M/B$ is computed as $(MINLP-BAU)/BAU$.

Thus, the significant 16.9% savings on the annual energy bill resulting from *MINLP* compared to *BAU* can be explained by at least one of these factors: better alignment with the power prices or lower power consumption – itself induced by lower discharge pressure or better pump efficiency.

²Assessed over the 365 instances, the cost difference between this formulation and the linear expression used as the objective (1) of the *MINLP* is around 3%.

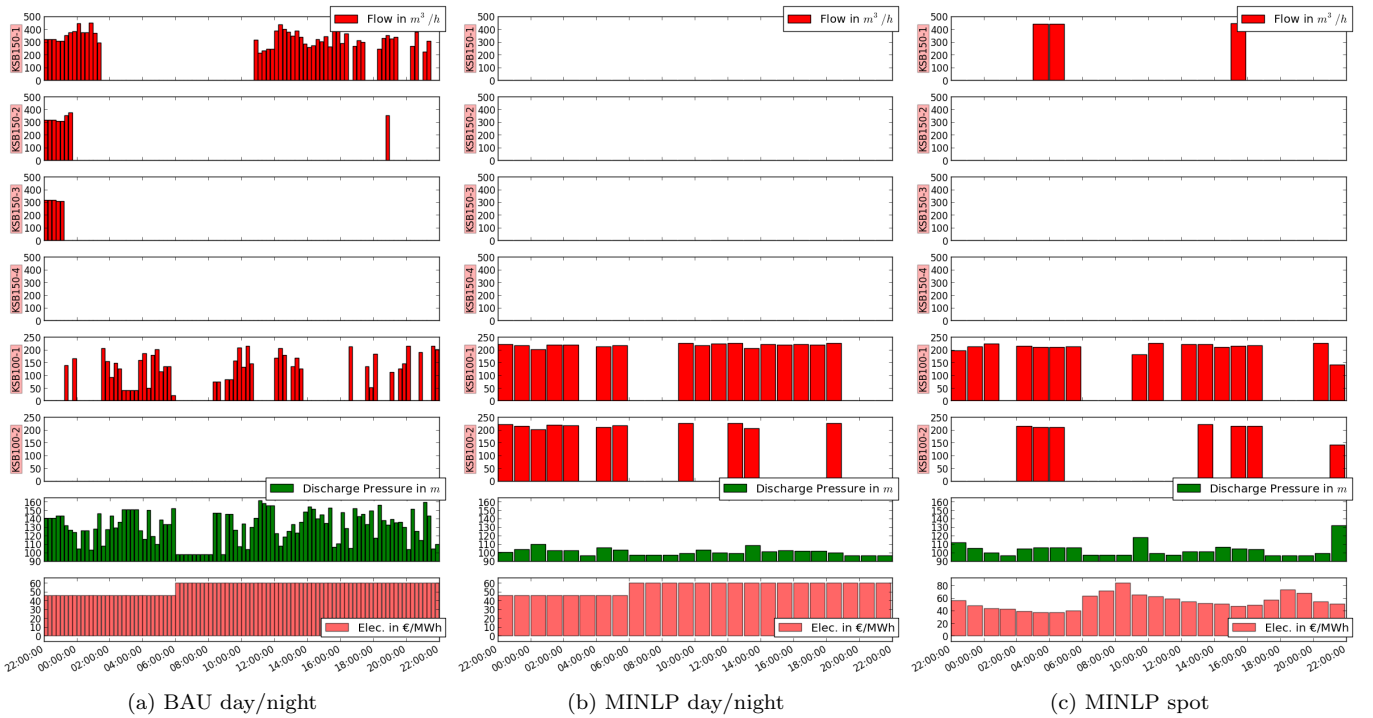

Figure 4: Comparison between the simulated strategy (*BAU*) and the optimized (*MINLP*) schedules on a winter day instance for two electricity tariffs (day/night and dynamic price). Top to bottom: in red, the schedule of the flow through the large (top four) and small (bottom two) pumps, the discharge pressure at node s , the electricity tariff.

Mean power cost. The alignment with the simple day/night tariff is comparable for the two strategies with an advantage for *MINLP*: the share of electricity consumed during the night is 17.4% greater for *MINLP* than for *BAU* and the share for the 4 hour-peak period is 96.6% lower. The mean cost of electricity decreases from €45.0/kWh for *BAU* to €43.1/kWh for *MINLP*. The price information is actually a key element of the scheduling decisions in both strategies, including in *BAU* where the fixed thresholds force the water towers to stay at their higher level during the night and at their lower level during the day.

Mean discharge pressure. *MINLP* provides a substantial reduction (13.3%) in annual energy consumption, driven by a 21.9% decrease in the mean discharge pressure. This lower pressure is clearly visible for the sample day depicted in Figures 4a and 4b (see green diagrams): the discharge pressure in *BAU* is frequently well above 110m which is the maximum pressure generated in *MINLP*. The reason for this is twofold. First, *MINLP* fills the water towers rationally over the time horizon, while *BAU* enforces a rapid fill of the towers at some time steps, involving larger instantaneous flows and more pressure losses in the pipes. In the illustrated example (see red diagrams), we observe that the filling of the water towers is well distributed over the off-peak period in *MINLP*, while in *BAU*, three large pumps send out a significant share of the water required during the first hour. Secondly, due to the binary status of the gate valves and the fixed amount of flow pass-

ing through them, at any time *BAU* must select one set of possible flow configurations from a finite number. Although the valves and pumps were jointly designed to fit the expected hydraulic conditions, any selected configuration of the valves may imply a substantial increase of the discharge pressure in order to reach the head-flow curves of the pumps. This can be observed on Figure 4a at 8:15am: although the flow is unlikely to substantially increase the discharge pressure (the flow is less than $100 \text{ m}^3/\text{h}$ and serves a water tower located in a low-altitude region), the discharge pressure has to be raised to 140 meters in order to intersect the head-flow curve of pump *KSB100-1*.

As an aside, the pressure decrease provided by *MINLP* also limits water leakages in the network. Indeed, water leakages are commonly modeled by an additional pressure-dependent demand at nodes [27, 31] and the frequency of pipe bursts also depends on the pressure [32]. Hence, minimizing the energy costs indirectly leads to positive externalities concerning leakages and maintenance costs.

Mean pump efficiency. The last factor we studied was the pump efficiency. We observed that the annual mean efficiency was reduced from 74.2% in *BAU* to 67.2% in *MINLP*. Figure 5 illustrates this gap on the winter day, by comparing the occurrence of the pump operating points of *BAU* (blue) and *MINLP* (yellow): *MINLP* chooses to move away from the best efficiency flow in order to reduce the discharge pressure, while the operating points in *BAU* are properly distributed all along the curves.

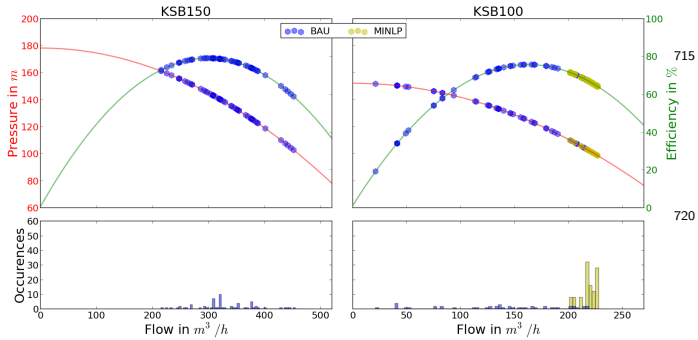

Figure 5: Operating points of the pumps for the two classes *KSB150* and *KSB100* in the daily schedules depicted in Figures 4a and 4b, computed respectively with strategies *BAU* and *MINLP*: cumulated (bottom graphs), and projected on the head-flow curve (in red) and the efficiency-flow curve (in green).

Hence, *MINLP* significantly reduces the energy costs compared to *BAU*, despite operating the pumps at lower efficiency levels. It is worth noting that we could expect more savings if the pumping station were designed in compliance with the *MINLP* approach, e.g. by right-translating the efficiency-flow curves of the pumps. To date, due to the limitation of the solvers, active network elements (like pumps, valves and tanks) are disregarded in the optimal design of water networks [15]. However, our results call for a study of a systemic approach that takes into account both the investment and the operational costs.

5.4. Load Shifting

The previous experiments validated the *MINLP* approach and illustrated the benefits in place of the current pumping strategy. Additionally, we estimated the robustness of *MINLP* to highly dynamic electricity tariffs. While *BAU* is mainly driven by water volume thresholds, which take into account half-day-based pricing, *MINLP* is theoretically compatible with hourly-based pricing. This type of strategy could thus be envisaged to implement load shifting at the pumping station, that is to take advantage of the water storage capacities in order to benefit from, and to contribute to, flexible power market conditions. To certify this usage, we experimented the same benchmark against the electricity price provided by the *European Electricity Index* [33]. Figure 4c depicts the solution obtained by *MINLP* for a sample day. As expected, dynamic pricing does not hinder the capacity of the approach to compute near-optimal solutions in very short times: at least one solution was found in 60 seconds for all of the 365 instances, and, with respect to the day/night pricing, the value of the mean optimality gap is only slightly higher (3.6%) and the maximal gap is of the same order (9.6%).

6. Conclusion and Future Works

This paper proposed a new mathematical programming approach for pump scheduling in a common class of

branched networks with one pumping station raising water to elevated tanks. Due to the presence of a flow control valve at each water tower, the equality constraints arising both from the pipe pressure loss and the pump head-flow constraints can be relaxed, making the *MINLP* convex and thus tractable with general-purpose solvers. We then show how to easily derive a feasible solution to the original problem and how to characterize its optimality gap.

We applied our approach to a real rural drinking water distribution network comprising 16 water towers, 31 pipes, and 6 pumps of 2 different classes. We experimented on 365 different instances, each corresponding to a day of historical water demand data. Using our approach, we were able to compute feasible solutions for all instances in less than 60 seconds with an average 3.0% optimality gap. The annual energy bill was 16.9% lower than a simulation of the current operational strategy based on water volume thresholds. Finally, the approach succeeded in optimizing when subject to hourly-based electricity prices, showing that it is suitable for implementing demand-response, in contrast with the current strategy.

Our approach has two main advantages compared to existing heuristic solutions: (1) it is able, in a very short time and for networks of a realistic size, to produce optimal or near-optimal solutions with performance guarantee, and (2) based on an adaptive model that can be handled by any appropriate black-box solver, it requires almost no software development and is easily reproducible.

In future works, our first aim will be to generalize the approach to other water networks. As the convex model remains valid, we need to figure out ways to build feasible solutions from the relaxation and to characterize the relaxation gap. Also, although a commercial solver can quickly solve the proposed convex program for the considered medium-size network, our approach still relies on solving an NP-hard problem. The limits of the approach in terms of network sizes and computation times should then be investigated in order to address larger branched networks. Finally, the question is how to integrate different network elements (e.g. specific valves, serial pumping stations, demand at junction, variable speed pumps, loops) to the relaxation without altering its performance.

Another research focus is to expand our approach for operational control to the entire decision process driving the management of water networks at different time scales. For the short term, our approach can easily be extended to real-time scheduling and embedded in a closed-loop control strategy [6]: as soon as the demand or the price diverges from the forecast, the model can be solved quickly, and the schedule can be repaired in line with the new solution. A practical question here is how the prediction errors deteriorate the solution quality. For the long term, our experimental results showed that significant benefits can be expected from tackling the whole optimization problem coupling design and scheduling in a systemic way; that is by simultaneously considering the operational costs with the investment and maintenance costs. *MINLP* approaches al-

ready exist for both design and scheduling and are closely based on the same core modeling elements. One open question is how to integrate the dynamic elements (pumps and valves) at the scale of the network design problem.

Acknowledgments

This work was partially funded by the Artemis Arrowhead project under grant agreement number 332987 (Artemis/Ecsel Joint Undertaking, supported by the European Commission and French Public Authorities).

References

- [1] P. K. Swamee, A. K. Sharma, Design of water supply pipe networks, John Wiley & Sons, 2008.
- [2] D. Denig-Chakroff, Reducing electricity used for water production: Questions state commissions should ask regulated utilities, Tech. rep., National Regulatory Research Institute (2008).
- [3] U. Shamir, Computer applications for real-time operation of water distribution systems, Computer Applications in Water Resources (1985) 379–390.
- [4] S. Ashok, R. Banerjee, Load-management applications for the industrial sector, Applied Energy 66 (2) (2000) 105–111.
- [5] B. Ghaddar, J. Naoum-Sawaya, A. Kishimoto, N. Taheri, B. Eck, A lagrangian decomposition approach for the pump scheduling problem in water networks, European Journal of Operational Research 241 (2) (2015) 490 – 501.
- [6] A. van Staden, J. Zhang, X. Xia, A model predictive control strategy for load shifting in a water pumping scheme with maximum demand charges, Applied Energy 88 (12) (2011) 4785 – 4794.
- [7] L. E. Ormsbee, K. E. Lansey, Optimal control of water supply pumping systems, Journal of Water Resources Planning and Management 120 (2) (1994) 237–252.
- [8] J. Nicklow, P. Reed, D. Savic, T. Dessaigne, L. Harrell, A. Chan-Hilton, M. Karamouz, B. Minsker, A. Ostfeld, A. Singh, et al., The ASCE task committee on evolutionary computation in environmental and water resources engineering. State of the art of genetic algorithms and beyond in water resources planning and management, Journal of Water Resources Planning and Management 136 (4) (2010) 412–432.
- [9] E. Price, A. Ostfeld, Iterative linearization scheme for convex nonlinear equations: Application to optimal operation of water distribution systems, Journal of Water Resources Planning and Management 139 (3).
- [10] M. Feldman, Aspects of energy efficiency in water supply systems, in: The 5th IWA water loss reduction Specialist Conference, Capetown, South Africa, 2009, pp. 85–89.
- [11] S. H. S. Bunn, Application of an expert system to control treated water distribution, in: WRPMD’99, 1999, pp. 1–7.
- [12] T. S. Engineering, Optimising water resource and supply systems, Wet News 5.
- [13] Innovyze, Balancenet, <http://www.innovyze.com/> (2015).
- [14] I. Pulido-Calvo, J. C. Gutiérrez-Estrada, Selection and operation of pumping stations of water distribution systems, Environmental Research Journal 5 (2011) 1–20.
- [15] C. D’Ambrosio, A. Lodi, S. Wiese, C. Bragalli, Mathematical programming techniques in water network optimization, European Journal of Operational Research 243 (3) (2015) 774 – 788.
- [16] Z. Zhang, Y. Zeng, A. Kusiak, Minimizing pump energy in a wastewater processing plant, Energy 47 (1) (2012) 505–514.
- [17] V. Puleo, M. Morley, G. Freni, D. Savić, Multi-stage linear programming optimization for pump scheduling, Procedia Engineering 70 (2014) 1378 – 1385, 12th International Conference on Computing and Control for the Water Industry.
- [18] D. Savić, G. Walters, M. Schwab, Multiobjective genetic algorithms for pump scheduling in water supply, in: D. Corne, J. Shapiro (Eds.), Evolutionary Computing, Vol. 1305 of Lecture Notes in Computer Science, Springer Berlin Heidelberg, 1997, pp. 227–235.
- [19] J. Burgschweiger, B. Gnädig, M. Steinbach, Optimization models for operative planning in drinking water networks, Optimization and Engineering 10 (1) (2009) 43–73.
- [20] P. Skworcow, D. Paluszczynszyn, B. Ulanicki, Pump schedules optimisation with pressure aspects in complex large-scale water distribution systems, Drinking Water Engineering and Science 7 (1) (2014) 53–62.
- [21] B. Geißler, O. Kolb, J. Lang, G. Leugering, A. Martin, A. Morsi, Mixed integer linear models for the optimization of dynamical transport networks, Mathematical Methods of Operations Research 73 (3) (2011) 339–362.
- [22] A. Morsi, B. Geißler, A. Martin, Mixed integer optimization of water supply networks, in: Mathematical Optimization of Water Networks, Springer, 2012, pp. 35–54.
- [23] D. Verleye, E.-H. Aghezzaf, Optimising production and distribution operations in large water supply networks: A piecewise linear optimisation approach, International Journal of Production Research 51 (23-24) (2013) 7170–7189.
- [24] L. B. de la Perrière, A. Jouglet, A. Nace, D. Nace, Water planning and management: An extended model for the real-time pump scheduling problem, in: Advances in hydroinformatics, Springer, 2014, pp. 153–170.
- [25] A. M. Gleixner, H. Held, W. Huang, S. Vigerske, Towards globally optimal operation of water supply networks, Numerical Algebra, Control and Optimization 2 (4) (2012) 695–711.
- [26] J. Naoum-Sawaya, B. Ghaddar, E. Arandia, B. Eck, Simulation-optimization approaches for water pump scheduling and pipe replacement problems, European Journal of Operational Research 246 (1) (2015) 293–306.
- [27] B. J. Eck, M. Mevissen, Valve placement in water networks: Mixed-integer non-linear optimization with quadratic pipe friction, Tech. rep., IBM Research Report (September 2012).
- [28] L. Rossman, EPANET Users Manu, United States Environmental Protection Agency (EPA), Cincinnati, OH (2000).
- [29] Arrêté du 30 octobre 2014 relatif aux tarifs de vente de l’électricité, Journal Officiel de la République Française (253).
- [30] The NEOS server, accessed 01.11.2015.
URL <http://www.neos-server.org/>
- [31] B. Ulanicki, P. Bounds, J. Rance, L. Reynolds, Open and closed loop pressure control for leakage reduction, Urban Water 2 (2) (2000) 105 – 114, developments in water distribution systems.
- [32] M. Fantozzi, A. Lambert, Including the effects of pressure management in calculations of short run economic leakage levels, in: IWA International Specialised Conference Water Loss, 2007.
- [33] ELIX european electricity index, accessed 05.08.2015.
URL <https://www.epexspot.com/en/market-data/elix>